

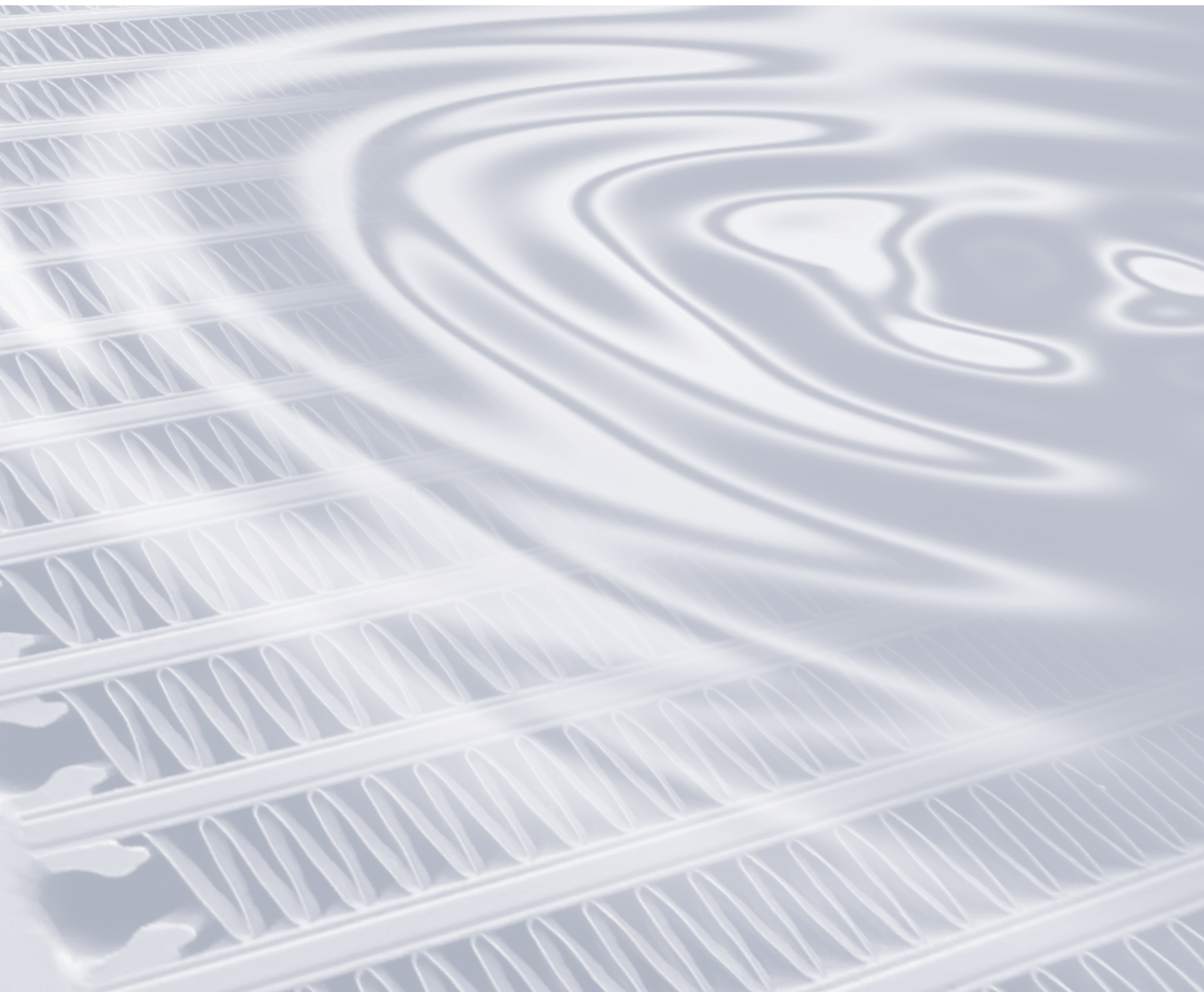

GLOBAL STANDARD COOLER
AKG-Line HR



RUGGED ENVIRONMENT COOLING SYSTEMS

PRODUCT INFORMATION

AKG-Line is a standard line of products from the market leader in high performance aluminium cooling systems. AKG is best known for its world-wide presence, German engineering and extremely reliable product quality on the one hand and very competitive prices on the other hand.

The **AKG-Line** type series consist of different models for mobile and stationary applications and are available through our global specialist dealer network. This line of products embraces all-purpose complete cooling systems that comply with European or American Standards, is suited for normal or rugged environmental operating conditions, is powered by AC-, DC- or hydraulic-motor-driven fans and is also available with noise-optimized models.

All of AKG's solutions have been developed with state-of-the-art technology, produced in compliance with the highest quality standards and are comprehensively tested in the company's own research and test facility.

FEATURES OF THE HR SERIES

- The coolers are equipped with anti-clogging fins
- High-Performance cooling assemblies
- Hydraulic motor powered fan
- The heat is transferred from the medium to be cooled to the ambient air
- Cooler can be universally used in hydraulic oil, transmission oil, engine oil, lubricating oil and coolant circuits
- For the cooling of mineral oil, synthetic oil, biological oil as well as of HFA, HFB, HFC and HFD liquids and water with at least 50 per cent of antifreeze and anticorrosive additives (other media available)
- Can be exposed to operating pressures of up to 26 bar or 17 bar, depending on model

BENEFITS

- Especially suited for rugged environments. Fin system prevents clogging and is easy to clean
- Highly flexible complete, ready-to-use cooling packages

- Compact and robust design, field-tested during many years of use in rugged real life conditions
- Largest and most comprehensive series of industrial and mobile hydraulic coolers
- Best heat transfer results per given cooler size due to comprehensive research and development
- Highest quality due to professional engineering and in-house manufacturing
- Available from stock or at short notice
- As a standard, equipped with **AKG's double-life** hollow sections designed to increase cooler service life

FLEXIBLE AKG HOLLOW PROFILE

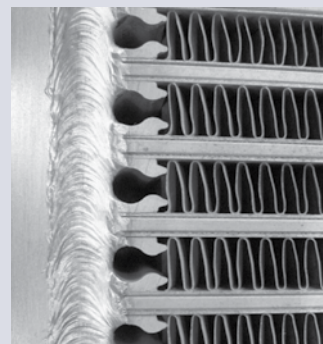

AKG-Line uses AKG hollow profiles to reduce local peak strains. This way the strength of heat exchangers is significantly increased and their service life time considerably prolonged.

AKG HOLLOW PROFILE FEATURES:

- **Reduced Strain:**
Strength calculations show that when using AKG hollow profiles maximum strain is reduced by a factor of 2
- **Prolonged Service Life Time:**
Extensive rig tests have shown that service life time increases by a factor ranging from 3 to 5

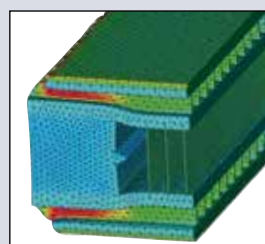

with standard profile

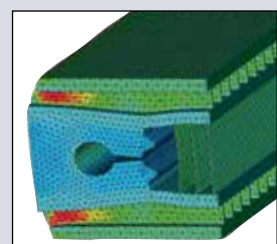

with hollow profile

EASY SIZING DIAGRAM

FOR ENTRANCE-TEMPERATURE-DIFFERENCE 60 K

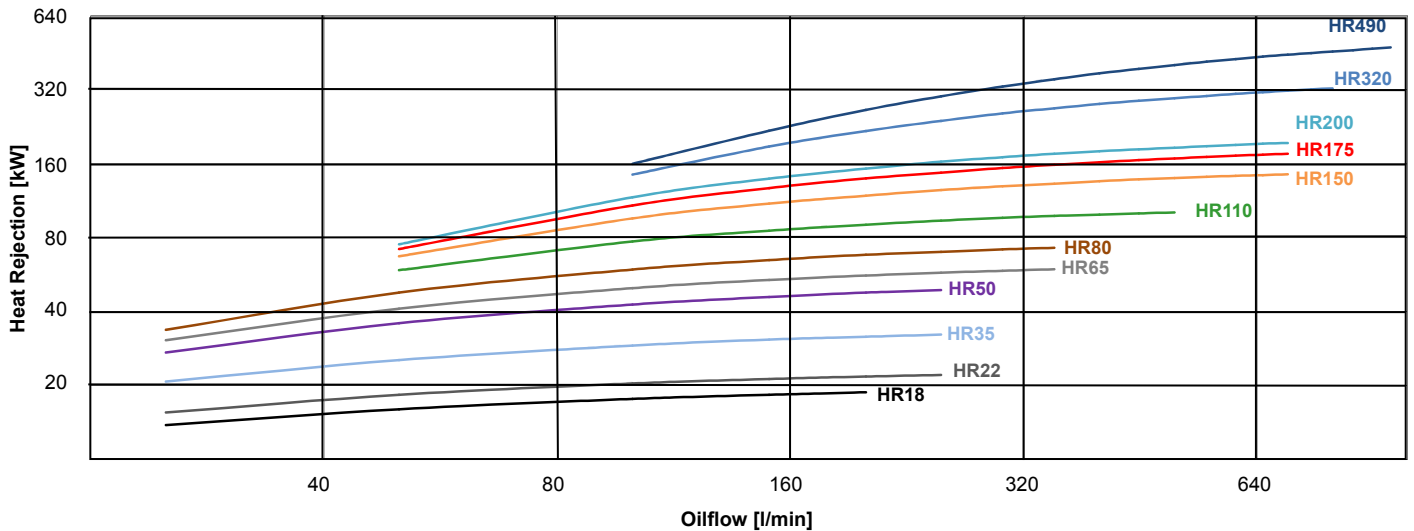

Selection by Specific Heat Rejection

1. Input Data:		Example
Required Heat Rejection	P =	130 kW
Oilflow through Cooler	V =	200 l/min
Oil Inlet Temperature	T _{Oil}	90 °C
Cooling Airflow Temperature	T _{CAF}	30 °C
2. Determination of Specific Heat Rejection:		
Entering-Temperature-Difference	ETD =	90 °C - 30 °C = 60 K
Required Specific Heat Rejection	P/ETD	130 kW/60 K = 2,2 kW/K
3. Select According to Diagram and Result:		Next higher curve HR 175

SPECIFIC HEAT REJECTION

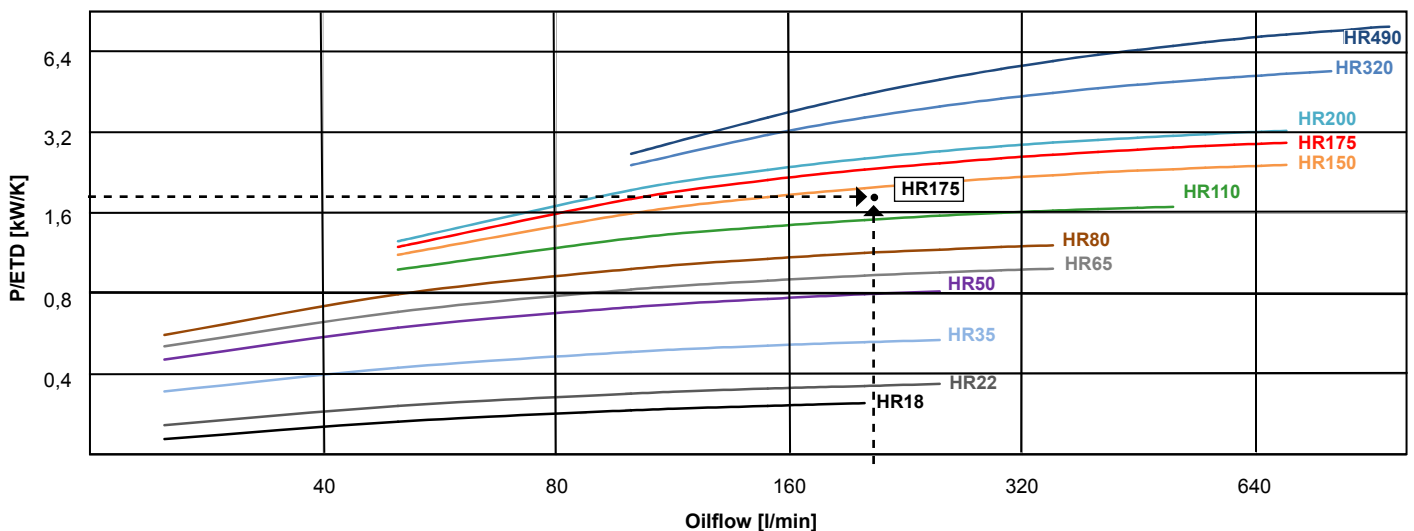

TECHNICAL DATA

Model Size	Motor Size (cm ³)	Max. Speed (rpm)	Nominal Speed (rpm)	Max. Motor Pressure (bar)	Approx. Noise level (dB(A), 1m)	Approx. Net Weight of Assembly (kg)	Volume (l)	Working Pressure (bar)
HR18	11	3500	3000	250	80	17	2,3	26
HR22	11	3500	3000	250	83	21	3,5	26
HR35	11	3500	1500	250	81	26	4,5	26
HR50	11	3500	1500	250	80	35	5	26
HR65	11	3000	1500	250	81	53	7,5	26
HR80	11	3000	1500	250	83	61	9	26
HR110	11	2500	1500	250	82	73	13,5	26
HR150	11	2500	1500	250	80	87	15	26
HR175	21	2500	1500	200	86	115	21	26
HR200	21	2500	1500	200	88	135	26	17
HR320	21	1500	1500	200	94	180	37	17
HR490	21	1450	1450	200	98	232	51	17

All data based on nominal fan speed conditions

DIMENSIONS

Model Size	A	B	C (approx.)	D	E	F	G	H	J	K	L	M
HR18	391	450	300	324	107	40	G1	392	180	220	M8	ø14
HR22	402	440	330	328	123	49	G1	382	240	280	M8	ø14
HR35	496	600	375	427	105	36	G1 1/4	542	180	220	M8	ø14
HR50	601	700	365	532	104	36	G1 1/4	638	180	220	M8	ø14
HR65	613	690	395	538	123	48	G1 1/4	632	240	280	M10	ø14
HR80	666	790	365	583	123	43	G1 1/4	732	240	280	M10	ø14
HR110	791	940	480	668	205	83	G1 1/2	882	340	380	M10	ø14
HR150	884	990	490	715	255	85	SAE 2"	932	340	380	M10	ø14
HR175	992	1040	515	820	255	82	SAE 2"	982	340	380	M10	ø14
HR200	989	1090	540	806	261	79	SAE 2"	1032	410	450	M12	ø14
HR320	1220	1240	560	1001	296	77	SAE 3"	1182	410	450	M12	ø14
HR490	1524	1340	560	1306	296	78	SAE 3"	1282	410	450	M12	ø14

All dimensions in mm

ORDERING INFORMATION

Serial Code: Model Size:

HR	
----	--

Optional Custom Features:

--

with:

with Blower Fan [B]
 with Resistplast Coating [+R]
 PTFE Based Coating [+T]
 with large Support Feet [+LF]

--

without:

without Motor [-M]
 without Motor, without Fan [-FM]
 Cooler Only [C]
 Cooler without Paint [-P]
 without Support Feet [-F]

Order Code Example: Rugged Environment Heat Exchanger, 100 KW, sucking Hydraulic fan -> **HR110**
 Rugged Environment Heat Exchanger, 190 KW, blowing Hydraulic fan -> **HR200B**

COOLER DIMENSIONS HR18 TO HR150

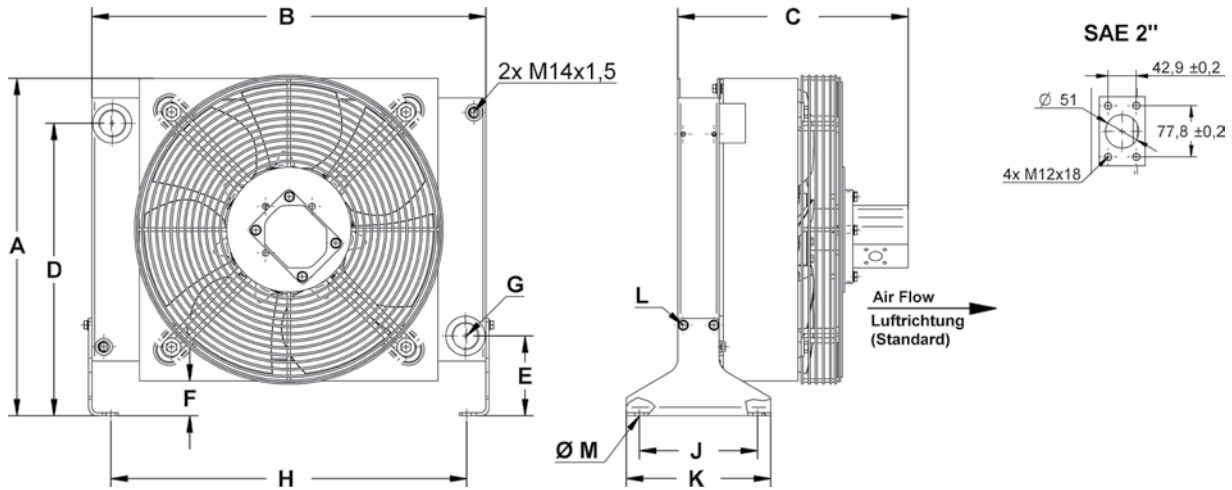

COOLER DIMENSIONS HR175 TO HR490

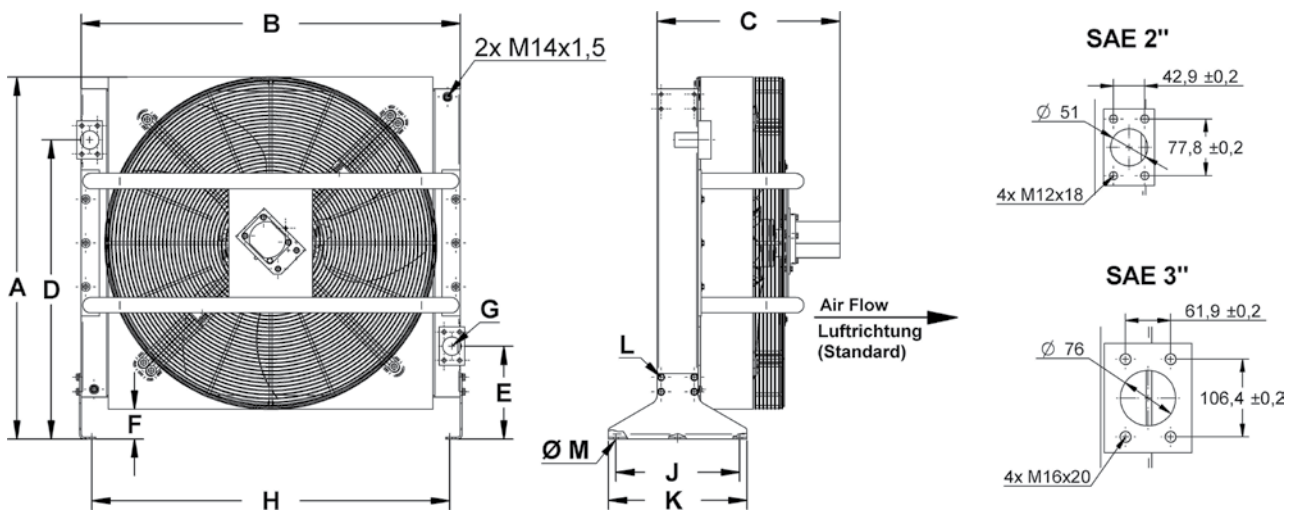

STANDARD SCOPE OF SUPPLY OF OIL-TO-AIR COOLING SYSTEM

- Cooler made of painted aluminium
- Plastic fan
- Fan-shroud, fingerguard, support feet and motorholder all made of steel (chromated or powder coated)
- Hydraulic motor



AKG UK Ltd.

St Hilary Court
Cophorne Way
Cardiff-CF5 6ES, United Kingdom
Phone: +44 1443 - 67 33 55
E-Mail: info@akg-uk.co.uk
Internet: www.akg-uk.co.uk

AKG – A STRONG GLOBALLY INTEGRATED GROUP OF COMPANIES

AKG is a globally leading supplier of high-performance coolers and heat exchangers as well as customised system solutions that comply with the highest quality standards.

On a world-wide scale 2,500 employees work at 12 manufacturing facilities located in Germany, France, Latvia, Turkey, the U.S.A., Brasil, China and India. Together with a number of additional oversea sales companies they are on duty around the clock.

Your AKG-Partner

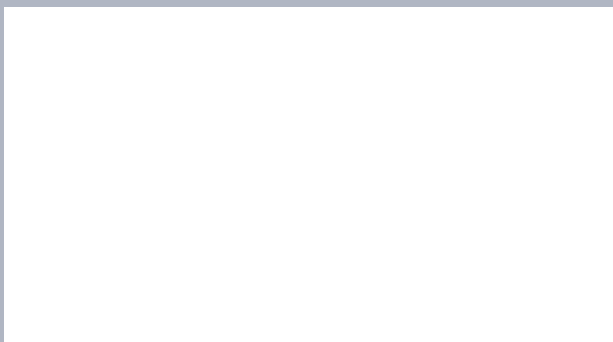

The longstanding and competent partnership with global OEM customers from 22 lines of business such as construction machinery, compressed-air systems, agricultural and forestry machines, vehicle construction and many other fields of application give fresh and innovative impetus to the mobile and industrial standard type series.

AKG operates one of the world's largest research, development, measurement and validation centres for cooling solutions and customised applications.

AKG's heat exchangers have stood for innovative solutions as well as highest engineering and manufacturing competence for more than 95 years.

Aluminium Coolers – Made by AKG
DIN EN ISO 9001