

SERIE BC

UTILIZZABILE NELLE PIÙ
GRAVOSE APPLICAZIONI

USABLE ALSO FOR
THE WORST APPLICATIONS

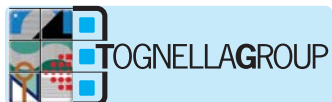

sesimo

The logo icon for sesimo, consisting of a white circle containing a red grid pattern.

LA SCIENZA DEL FREDDO • THE SCIENCE OF COLD



INDICE

BC 210 12-24



4

BC 210 *MONOFASE SINGLE-PHASE*
TRIFASE THREE-PHASE

6

BC 250 12-24



8

BC 250 *MONOFASE SINGLE-PHASE*
TRIFASE THREE-PHASE

10

BC 250/2 12-24



12

BC 250/2 *MONOFASE SINGLE-PHASE*
TRIFASE THREE-PHASE

14

BC 390 12-24



16

BC 390 *MONOFASE SINGLE-PHASE*
TRIFASE THREE-PHASE

18

BC 390/2 12-24



20

BC 390/2 *MONOFASE SINGLE-PHASE*
TRIFASE THREE-PHASE

22

SERIE BC

Questa serie di scambiatori adotta un nuovo tipo di pacco radiante che è un'assoluta novità tecnologica, sostanzialmente diverso da tutti quelli attualmente presenti sul mercato.

Esso è naturalmente in alluminio ed è costituito da un insieme di piastre stampate in una particolare forma che consente, dopo l'operazione di saldatura in forno ad atmosfera controllata, di ottenere lo scambiatore finito, senza avere quindi la necessità di saldare successivamente le vasche collettrici.

Ciò naturalmente abbrevia e semplifica il ciclo produttivo, con conseguente diminuzione del costo di produzione.

La definizione di questo nuovo pacco radiante è costata due anni di progettazione, prove, rifacimento stampi, fino a giungere al risultato finale altamente soddisfacente per quanto riguarda la resistenza alla pressione sia statica sia dinamica che è sempre stata una caratteristica negativa dei pacchi radianti di questo tipo.

Ora siamo in grado di garantire pressioni di tutto rispetto, seppur inferiori a quelle dei nostri scambiatori serie APL: massima pressione statica 25 bar, massima pressione dinamica 16 bar; riteniamo che con tali

pressioni si possano coprire notevoli campi di impiego in oleoidraulica.

Un'ulteriore novità che possiamo offrire su questa nuova serie è la possibilità di applicazione di una valvola di by-pass integrata, con il compito di proteggere il pacco radiante dalle sovrappressioni causate da portate olio istantanee elevate o partenze a freddo nella stagione invernale. La taratura standard della valvola è 4 bar.

Le parti in lamiera di acciaio sono trattate convenientemente per evitare la formazione di ruggine durante la permanenza alle intemperie.

Come optional questi scambiatori possono essere forniti con termostato avente taratura 60°C o 47°C a scelta e protezione IP 65. sempre come optional può essere richiesta la fornitura dell'impianto elettrico già cablato.

Questa serie può essere fornita con ventilatori a corrente continua, 12 o 24V, o a corrente alternata mono o trifase.

SERIE BC

This series of heat exchangers uses a new type of cooling element which is a completely new technological product, significantly different from all of those currently offered on the market.

Naturally it is made in aluminium and from specially shaped molded parts that allow, after welding in an oven under a controlled atmosphere, to obtain the finished heat exchanger, without the need to further weld the tanks. This shortens and simplifies the production cycle, and consequently reduces the production costs.

The definition of this new radiant package has been obtained at the cost of two years of design, tests, and remaking molds. The final result is highly satisfying in terms of both the static and dynamic pressure resistance which is normally a negative characteristic of the radiant package of this type.

We are now able to guarantee respectable pressures, even if they are lower than those of our APL serie heat exchangers: maximum static pressure 25 bar, maximum dynamic pressure 16 bar. It is our belief that these pressures can cover a wide field of use in hydraulic applications.

Another option that we are offering on this

new series is the possible application of an integrated by-pass valve, which protects the cooling element from excess pressure caused by elevated instantaneous oil flow rates, or cold starts during the winter. The standard calibration of the valve is 4 bar.

The steel sheet metal parts have been conveniently treated to avoid the formation of rust during exposure to bad weather.

As an optional feature, these heat exchangers can be supplied with a thermostat calibrated at a choice of 60°C or 47°C and with IP 65 protection. Also as an optional, another options is to have the electrical system already pre-cabled.

This serie can be supplied with fans powered with 12 or 24 V direct current, or single or tri-phase alternating current.

**SCAMBIATORI
SERIE BC
EXCHANGERS
BC SERIE**

SERIE BC

resino
4



DIAGRAMMA DI RENDIMENTO
PERFORMANCE DIAGRAM



DIAGRAMMA PERDITE DI CARICO
LOSS PRESSURE DIAGRAM

22	30	46	68	100	150	220
0,6	1	1,5	2,3	3,5	5	7

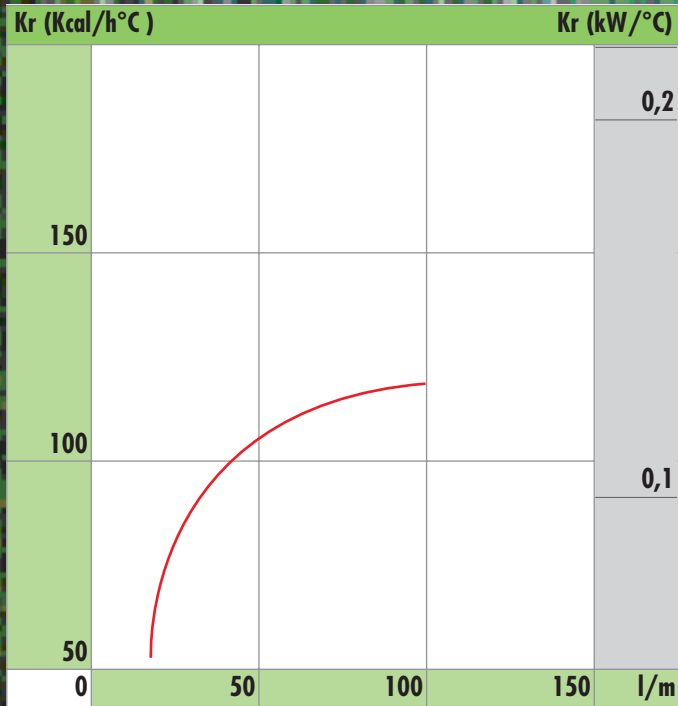
FATTORE DI CORREZIONE
CORRECTION FACTOR

BC 210 12-24

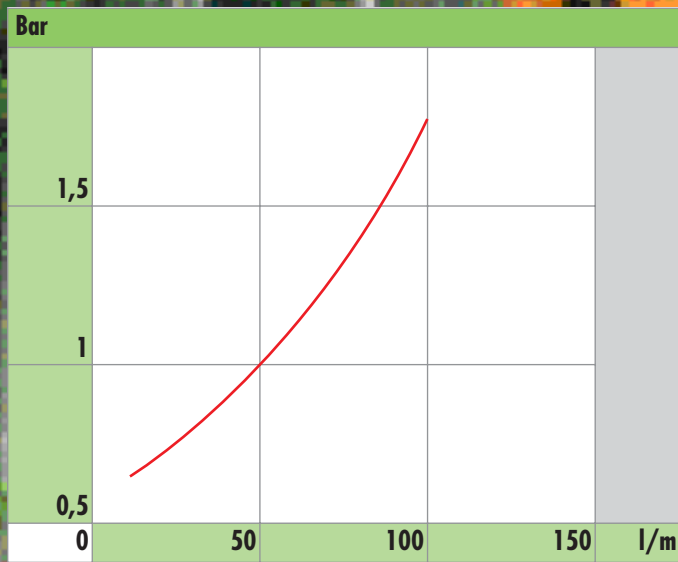

**DIMENSIONI E CARATTERISTICHE
TECNICHE NON IMPEGNATIVE
DIMENSIONS AND TECHNICAL
CHARACTERISTICS ARE NOT BINDING**

BC 210	Capacità Capacity	Tensione Voltage	Potenza Power	Corrente Current	Portata aria Air flow	Protezione Protection	Rumorosità Noise Level	Peso Weight
Tipo-Type	I	V	W	A	m ³ /h	IP	dB(A)	Kg
BC 210 12	1,7	12	70	5,8	600	64	75	6
BC 210 24		24		2,9				

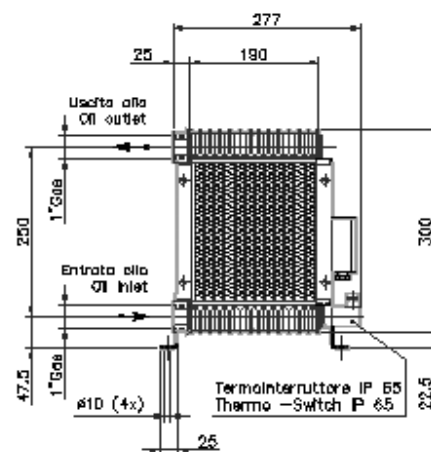
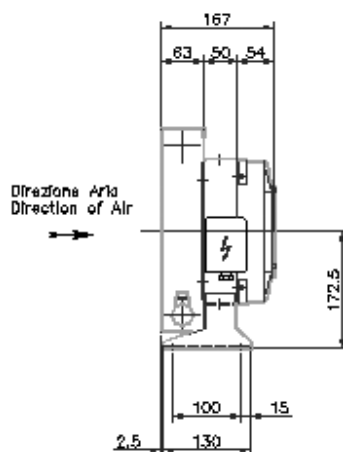
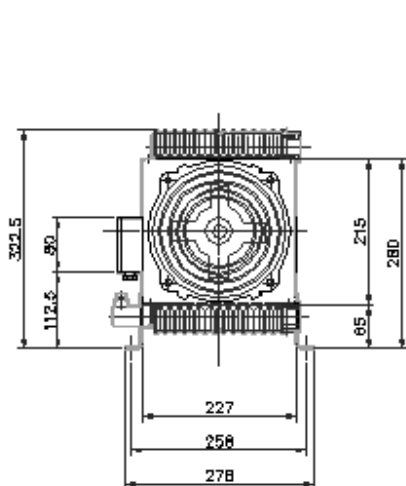

SERIE BC

resino
6



DIAGRAMMA DI RENDIMENTO
PERFORMANCE DIAGRAM



DIAGRAMMA PERDITE DI CARICO
LOSS PRESSURE DIAGRAM

22	30	46	68	100	150	220
0,6	1	1,5	2,3	3,5	5	7

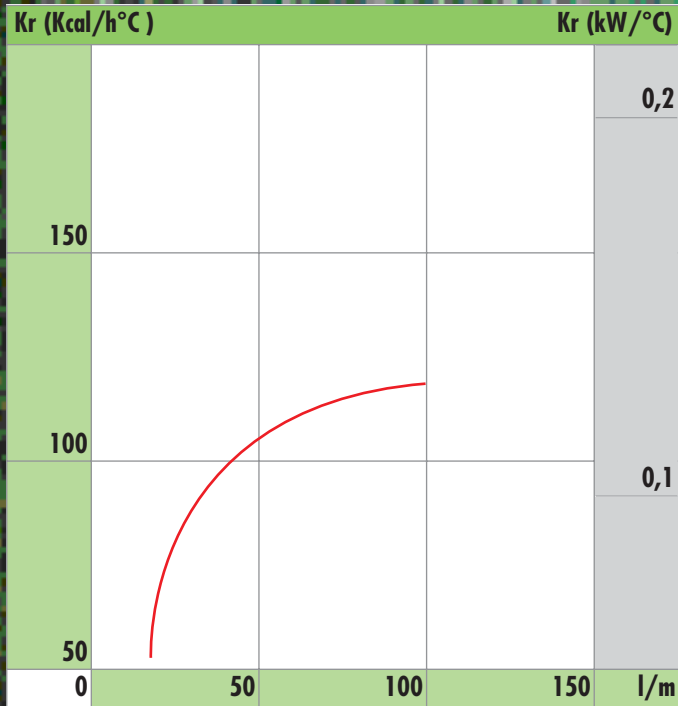
FATTORE DI CORREZIONE
CORRECTION FACTOR

BC 210 MONOFASE TRIFASE

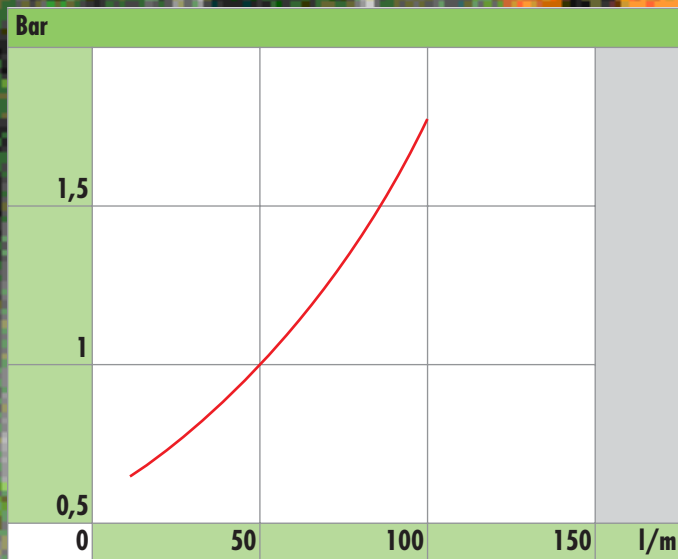

**DIMENSIONI E CARATTERISTICHE
TECNICHE NON IMPEGNATIVE
DIMENSIONS AND TECHNICAL
CHARACTERISTICS ARE NOT BINDING**

BC 210	Portata olio Oil flow	Capacità Capacity	Tensione Voltage	Frequenza Frequency	Potenza Power	Corrente Current	Portata d'aria Air flow	Protezione Protection	Rumorosità Noise Level	Peso Weight
Tipo-Type		l	V	Hz	W	A	m ³ /h	IP	dB(A)	Kg
BC 210 monofase	25-100	1,7	230	50/60	62	0,27	630	44	57	7
BC 210 trifase			230-400		68/70					

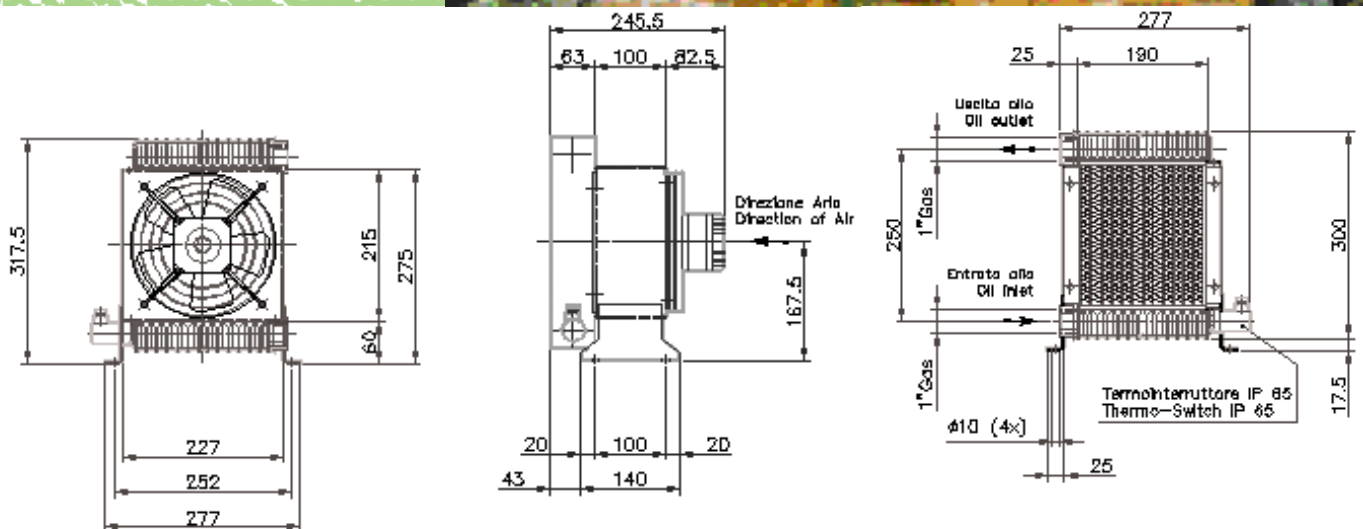

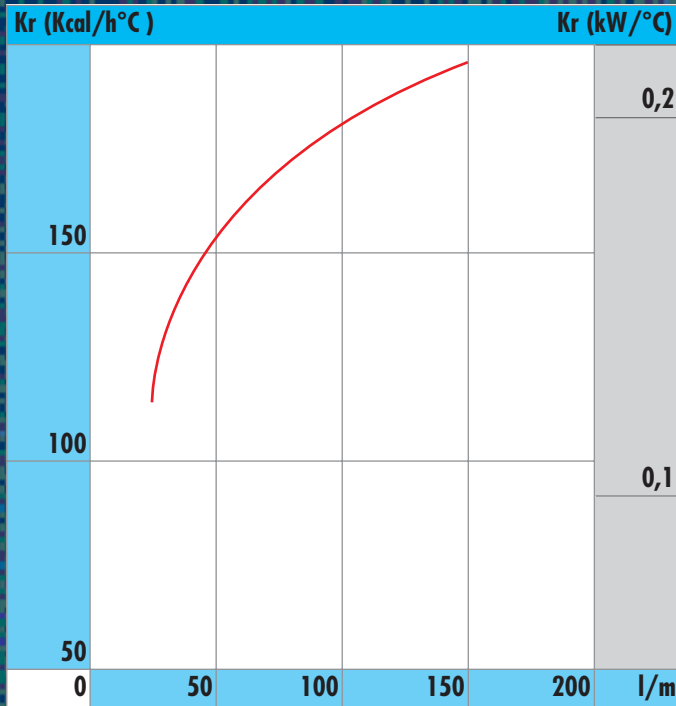

**DIAGRAMMA DI RENDIMENTO
PERFORMANCE DIAGRAM**

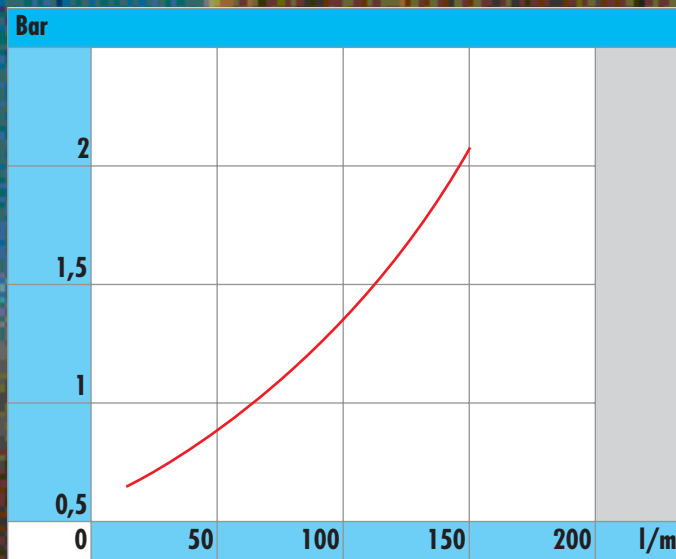

**DIAGRAMMA PERDITE DI CARICO
LOSS PRESSURE DIAGRAM**

22	30	46	68	100	150	220
0,6	1	1,5	2,3	3,5	5	7

**FATTORE DI CORREZIONE
CORRECTION FACTOR**

BC 250 12-24

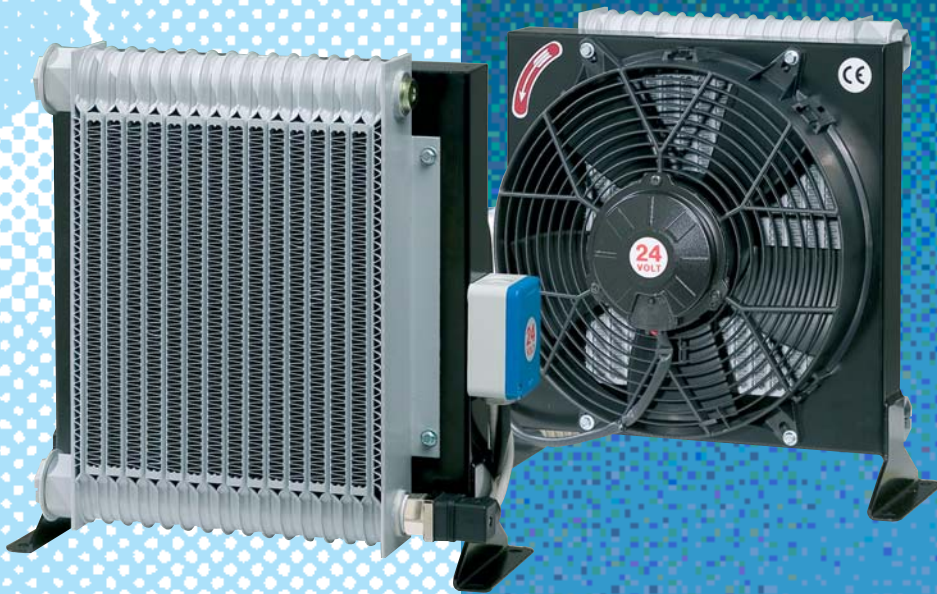

**DIMENSIONI E CARATTERISTICHE
TECNICHE NON IMPEGNATIVE
DIMENSIONS AND TECHNICAL
CHARACTERISTICS ARE NOT BINDING**

BC 250	Capacità Capacity	Tensione Voltage	Potenza Power	Corrente Current	Portata aria Air flow	Protezione Protection	Rumorosità Noise Level	Peso Weight
Tipo-Type	1	V	W	A	m ³ /h	IP	dB(A)	Kg
BC 250 12	2	12	180	15	1.600	68	79	10
BC 250 24		24		7,5				

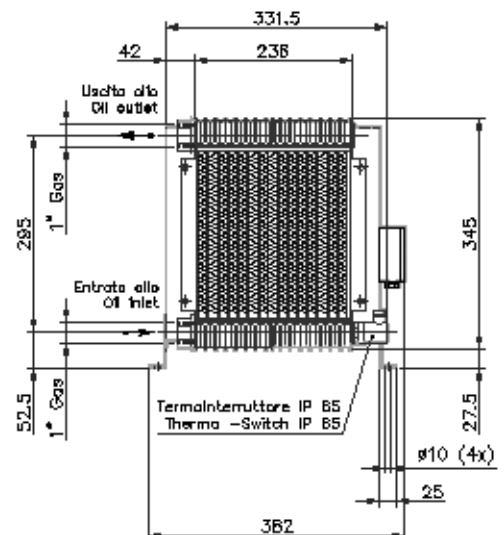
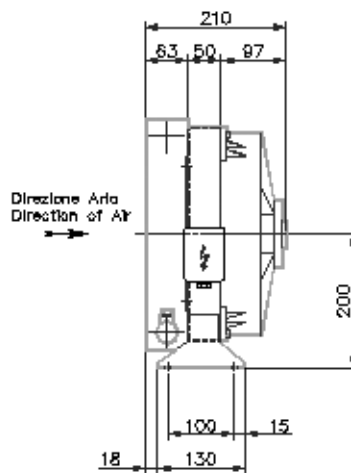
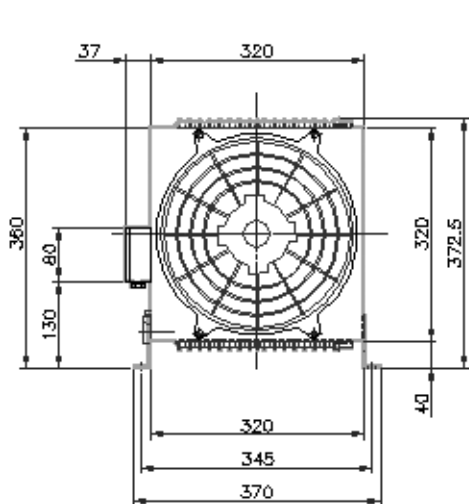

SERIE BC

resino
10



DIAGRAMMA DI RENDIMENTO
PERFORMANCE DIAGRAM



DIAGRAMMA PERDITE DI CARICO
LOSS PRESSURE DIAGRAM

22	30	46	68	100	150	220
0,6	1	1,5	2,3	3,5	5	7

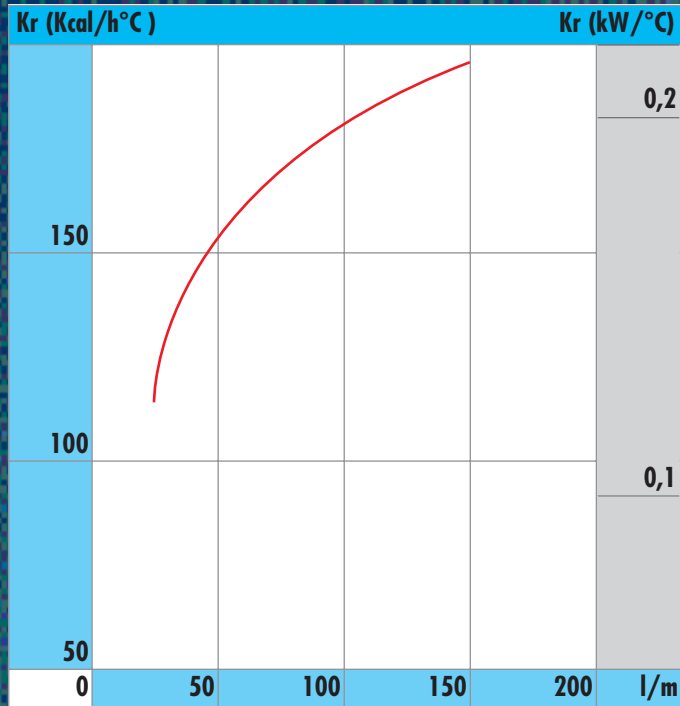
FATTORE DI CORREZIONE
CORRECTION FACTOR

BC 250 MONOFASE TRIFASE

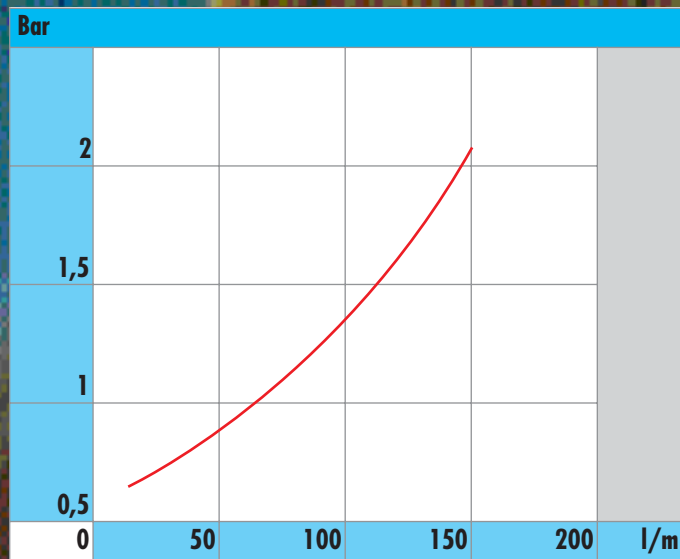

DIMENSIONI E CARATTERISTICHE TECNICHE NON IMPEGNATIVE
DIMENSIONS AND TECHNICAL CHARACTERISTICS ARE NOT BINDING

BC 250	Portata olio Oil flow	Capacità Capacity	Tensione Voltage	Frequenza Frequency	Potenza Power	Corrente Current	Portata d'aria Air flow	Protezione Protection	Rumorosità Noise Level	Peso Weight
Tipo-Type		l	V	Hz	W	A	m ³ /h	IP	dB(A)	Kg
BC 210 monofase	25-150	2	230	50/60	120/160	0,53/0,7	950	44	73	12
BC 210 trifase			230-400		105/145				0,19/0,23	

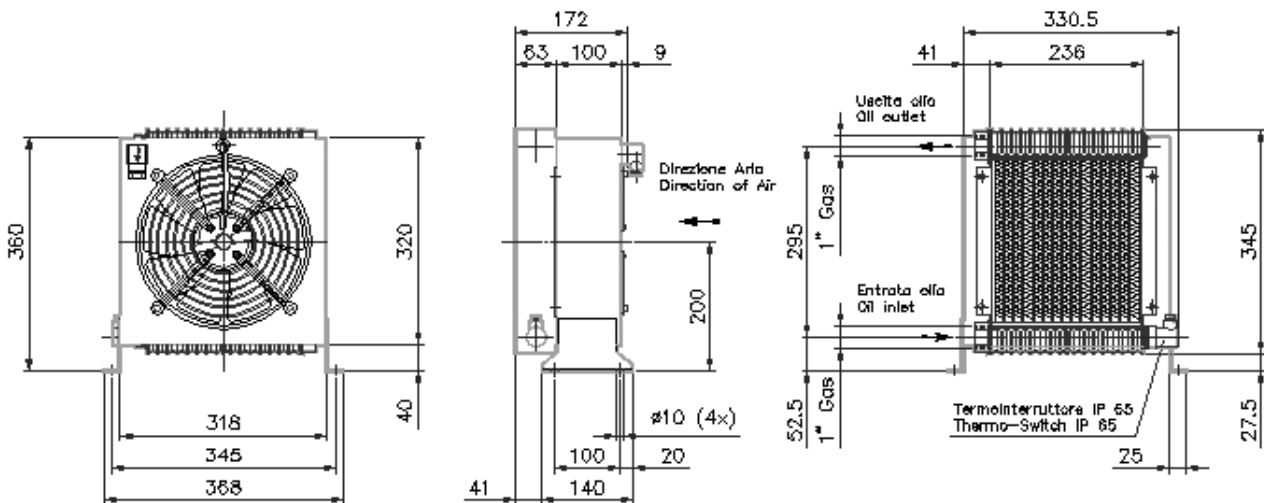

SERIE BC

resino
12



DIAGRAMMA DI RENDIMENTO
PERFORMANCE DIAGRAM



DIAGRAMMA PERDITE DI CARICO
LOSS PRESSURE DIAGRAM

22	30	46	68	100	150	220
0,6	1	1,5	2,3	3,5	5	7

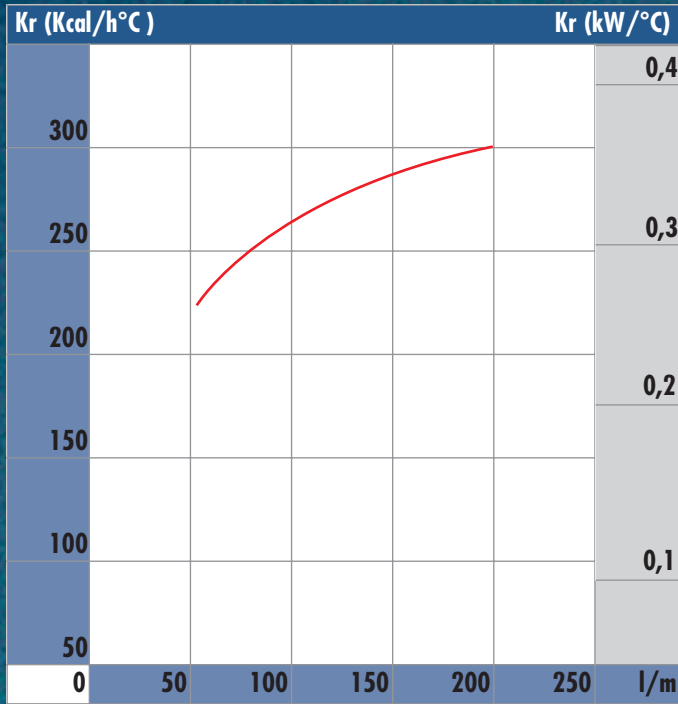
FATTORE DI CORREZIONE
CORRECTION FACTOR

BC 250/2 12-24

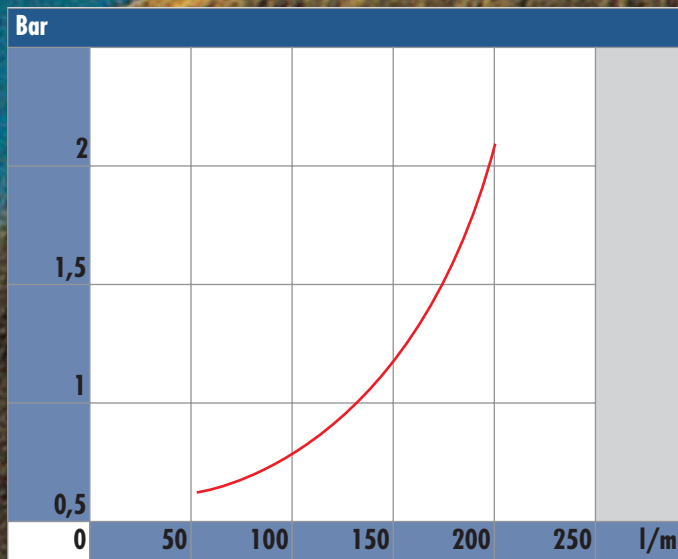
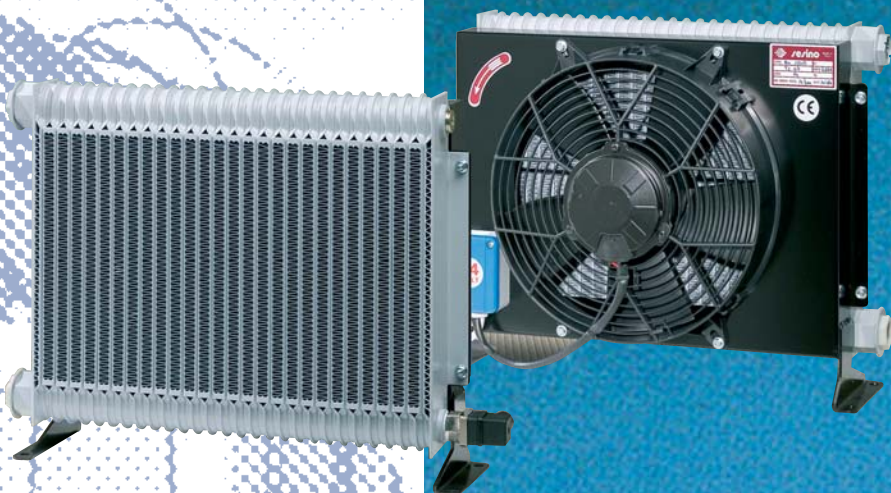

**DIMENSIONI E CARATTERISTICHE
TECNICHE NON IMPEGNATIVE
DIMENSIONS AND TECHNICAL
CHARACTERISTICS ARE NOT BINDING**

BC 250/2	Capacità Capacity	Tensione Voltage	Potenza Power	Corrente Current	Portata aria Air flow	Protezione Protection	Rumorosità Noise Level	Peso Weight
Tipo-Type	l	V	W	A	m ³ /h	IP	dB(A)	Kg
BC 250/2 12	4	12	180	15	2.200	68	83	14
BC 250/2 24		24		7,5				

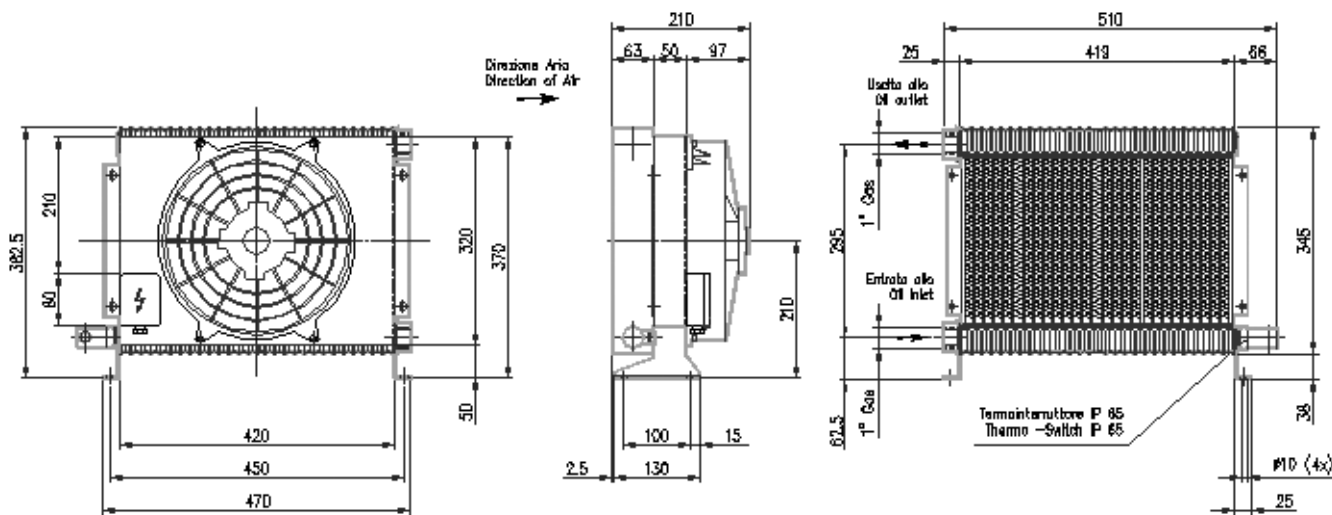

SERIE BC

resino
14



DIAGRAMMA DI RENDIMENTO
PERFORMANCE DIAGRAM



DIAGRAMMA PERDITE DI CARICO
LOSS PRESSURE DIAGRAM

22	30	46	68	100	150	220
0,6	1	1,5	2,3	3,5	5	7

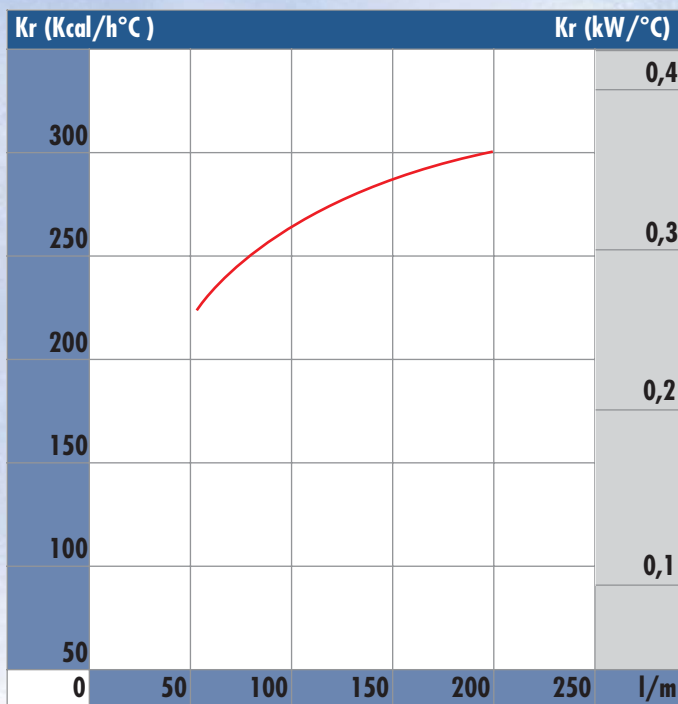
FATTORE DI CORREZIONE
CORRECTION FACTOR

BC 250/2 MONOFASE TRIFASE

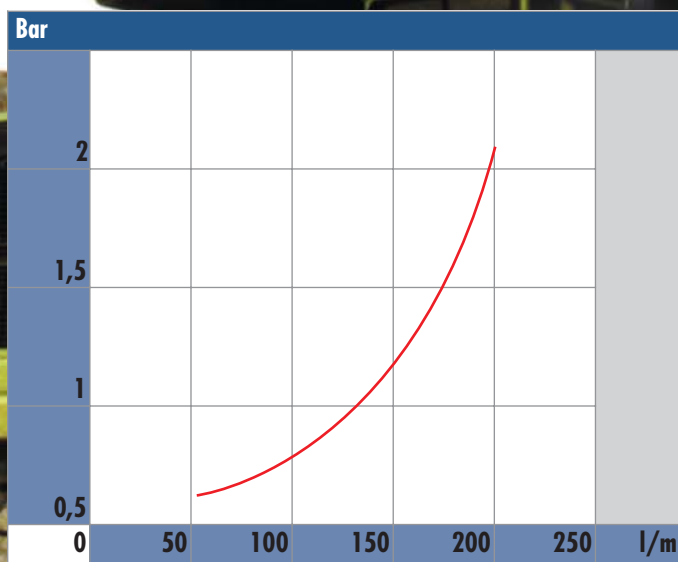
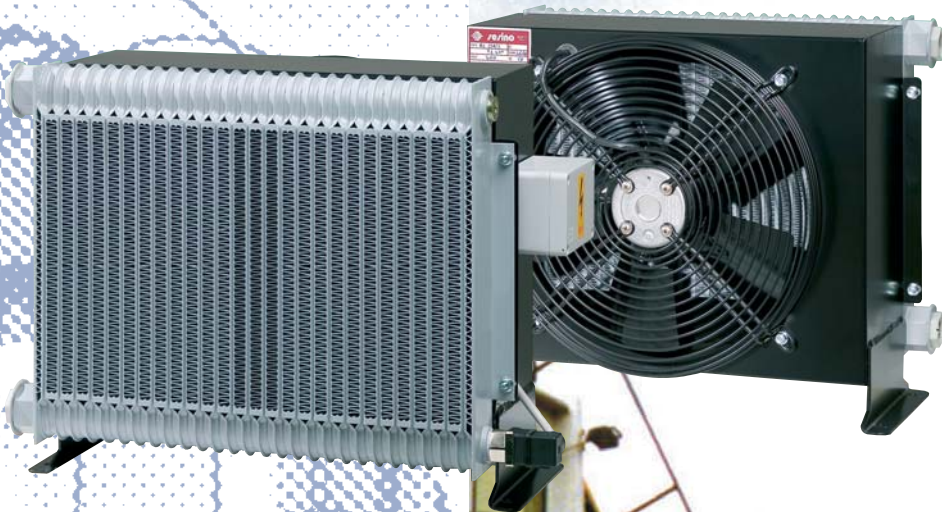

DIMENSIONI E CARATTERISTICHE TECNICHE NON IMPEGNATIVE
DIMENSIONS AND TECHNICAL CHARACTERISTICS ARE NOT BINDING

BC 250/2	Portata olio Oil flow	Capacità Capacity	Tensione Voltage	Frequenza Frequency	Potenza Power	Corrente Current	Portata d'aria Air flow	Protezione Protection	Rumorosità Noise Level	Peso Weight
Tipo-Type		l	V	Hz	W	A	m ³ /h	IP	dB(A)	Kg
BC 250/2 monofase	50-200	4	230	50/60	230/350	1,1/1,55	1.500	44	73	16
BC 250/2 trifase			230-400		95/110	0,21/0,22			75	

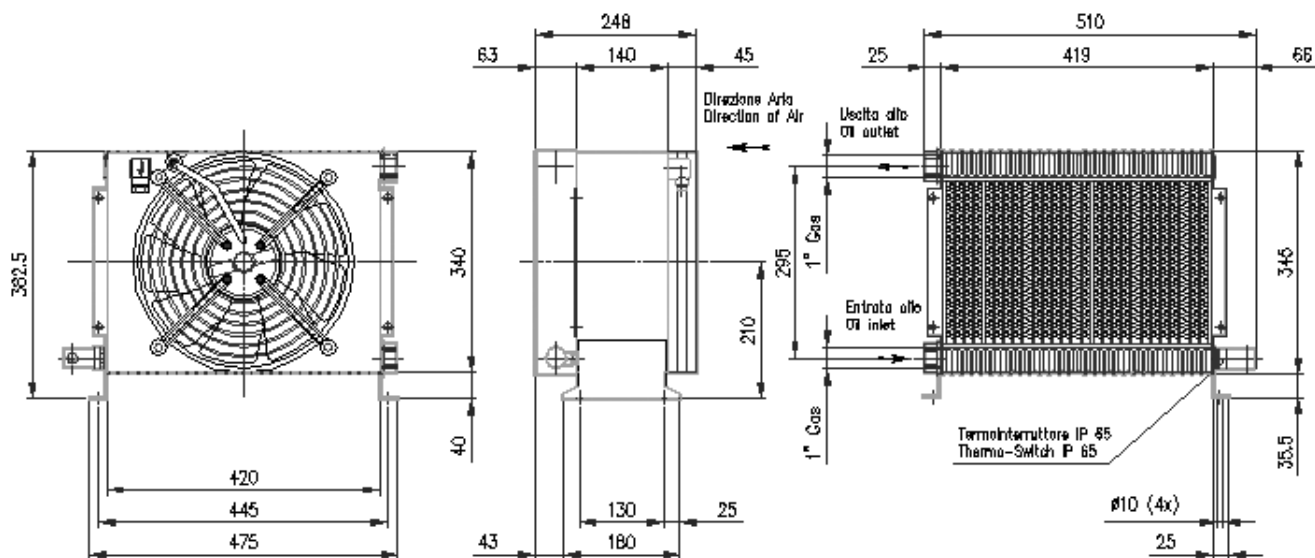

SERIE BC

resino
16

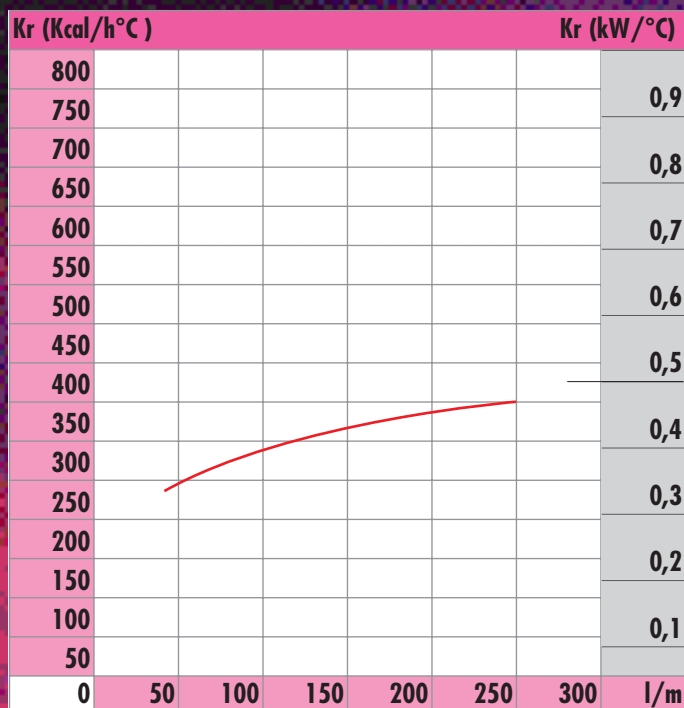

**DIAGRAMMA DI RENDIMENTO
PERFORMANCE DIAGRAM**

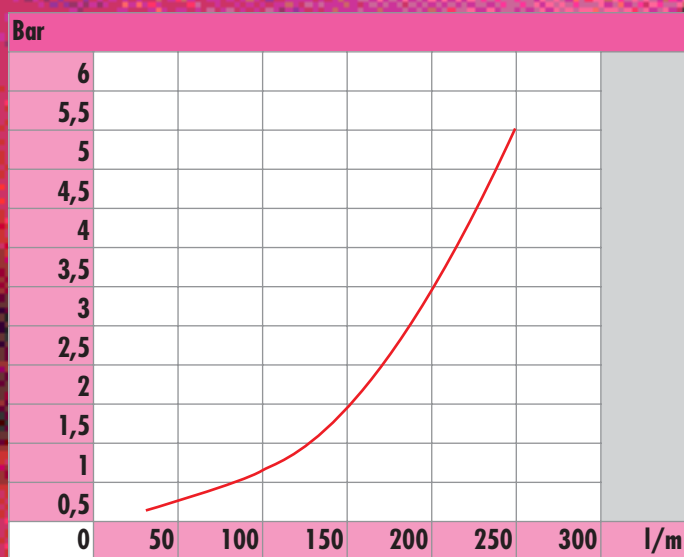

**DIAGRAMMA PERDITE DI CARICO
LOSS PRESSURE DIAGRAM**

22	30	46	68	100	150	220
0,6	1	1,5	2,3	3,5	5	7

**FATTORE DI CORREZIONE
CORRECTION FACTOR**

BC 390 12-24



DIMENSIONI E CARATTERISTICHE TECNICHE NON IMPEGNATIVE DIMENSIONS AND TECHNICAL CHARACTERISTICS ARE NOT BINDING

BC 390	Capacità Capacity	Tensione Voltage	Potenza Power	Corrente Current	Portata aria Air flow	Protezione Protection	Rumorosità Noise Level	Peso Weight
Tipo-Type	l	V	W	A	m ³ /h	IP	dB(A)	Kg
BC 390 12	5	12	240	20	2.500	68	85	16
BC 390 24		24		10				

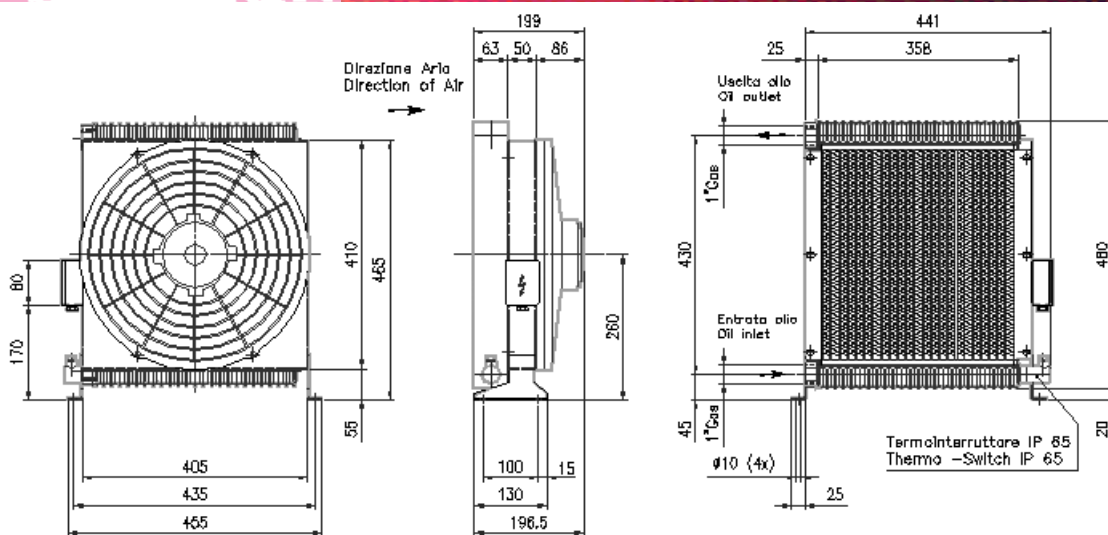

SERIE BC

resino
18



DIAGRAMMA DI RENDIMENTO
PERFORMANCE DIAGRAM



DIAGRAMMA PERDITE DI CARICO
LOSS PRESSURE DIAGRAM

22	30	46	68	100	150	220
0,6	1	1,5	2,3	3,5	5	7

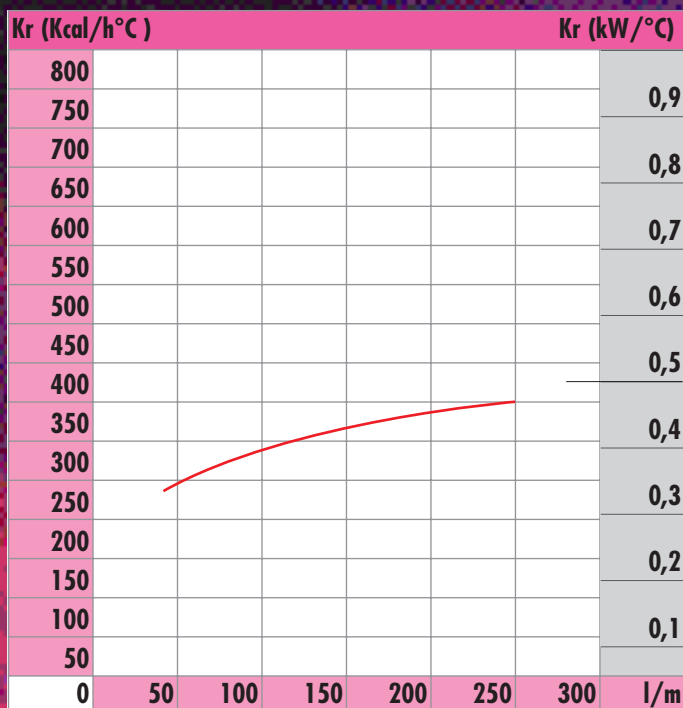
FATTORE DI CORREZIONE
CORRECTION FACTOR

BC 390 MONOFASE TRIFASE

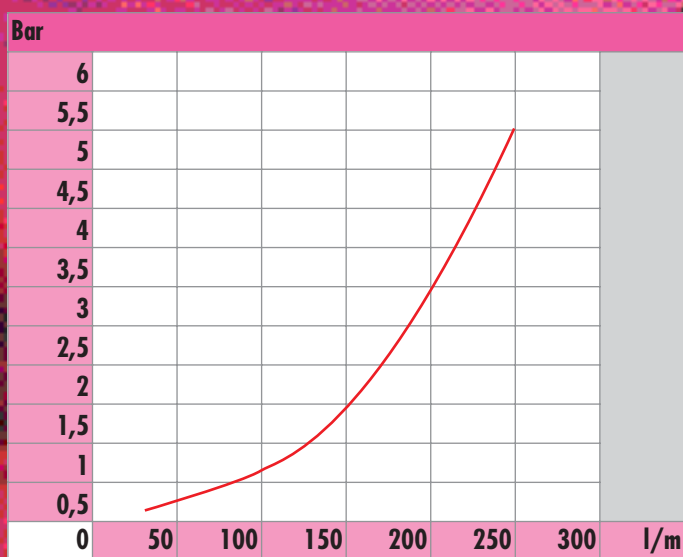
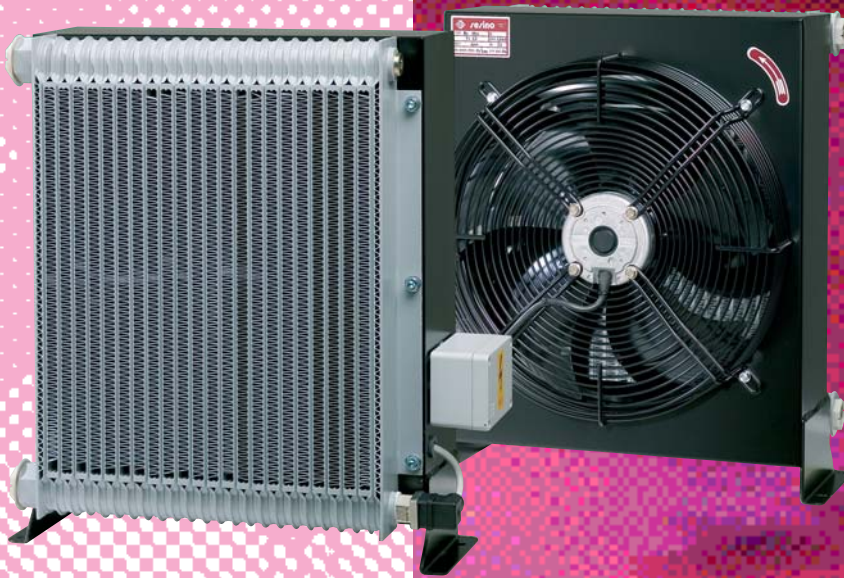

**DIMENSIONI E CARATTERISTICHE
TECNICHE NON IMPEGNATIVE
DIMENSIONS AND TECHNICAL
CHARACTERISTICS ARE NOT BINDING**

BC 390	Portata olio Oil flow	Capacità Capacity	Tensione Voltage	Frequenza Frequency	Potenza Power	Corrente Current	Portata d'aria Air flow	Protezione Protection	Rumorosità Noise Level	Peso Weight
Tipo-Type		l	V	Hz	W	A	m ³ /h	IP	dB(A)	Kg
BC 390 monofase	50-250	5	230	50-60	90/110	0,9/1	2.500	55	73	19
BC 390 trifase			230/400		150/250					

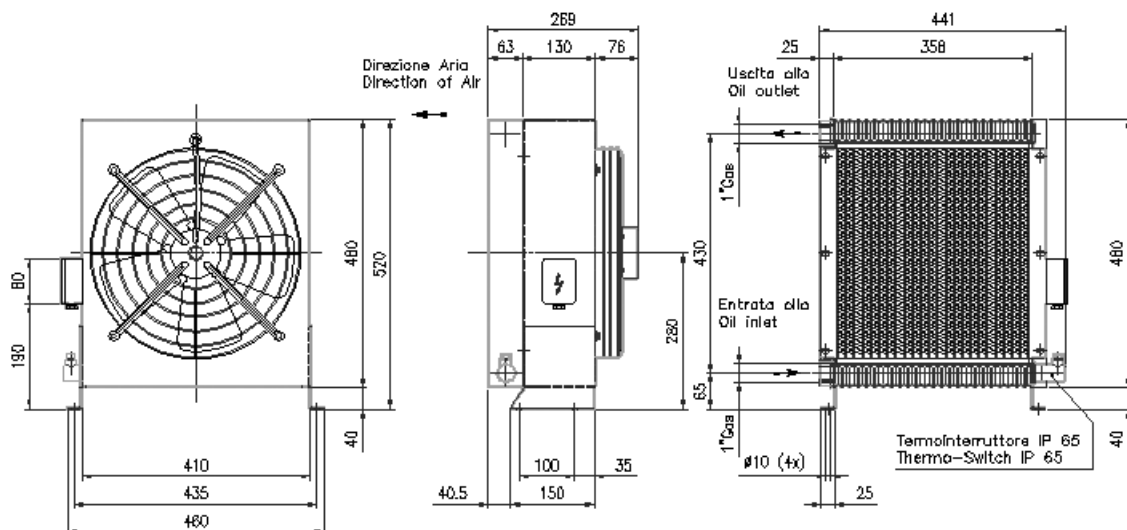

SERIE BC

resino
20



DIAGRAMMA DI RENDIMENTO
PERFORMANCE DIAGRAM



DIAGRAMMA PERDITE DI CARICO
LOSS PRESSURE DIAGRAM

22	30	46	68	100	150	220
0,6	1	1,5	2,3	3,5	5	7

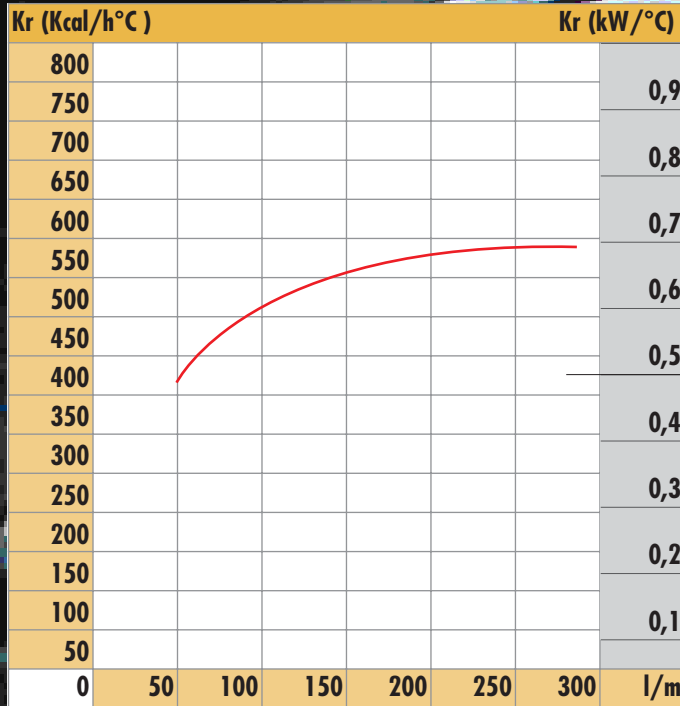
FATTORE DI CORREZIONE
CORRECTION FACTOR

BC 390/2 12-24

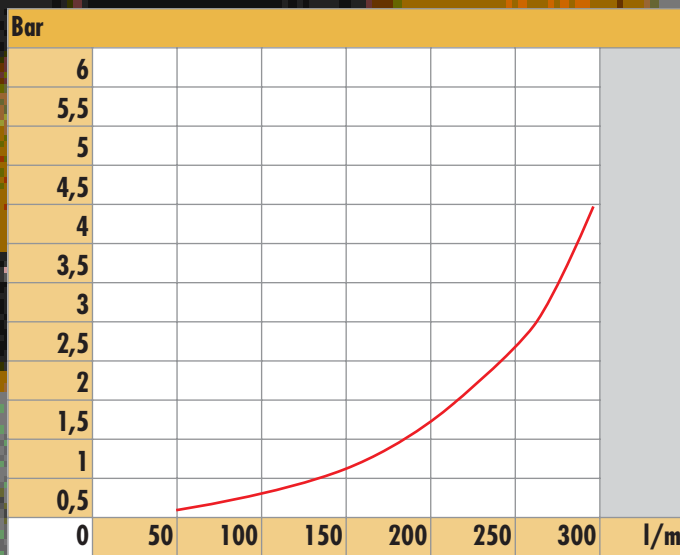
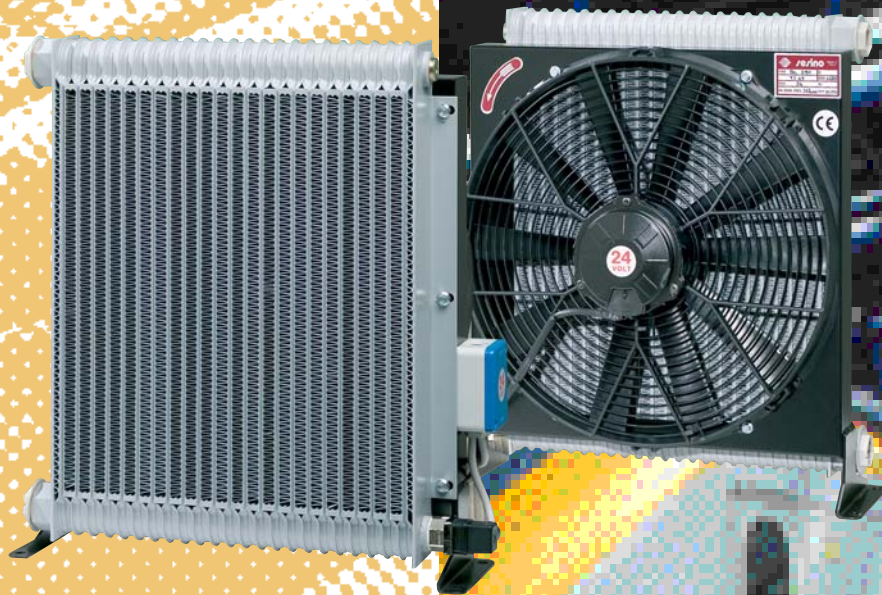

**DIMENSIONI E CARATTERISTICHE
TECNICHE NON IMPEGNATIVE
DIMENSIONS AND TECHNICAL
CHARACTERISTICS ARE NOT BINDING**

BC 390/2	Capacità Capacity	Tensione Voltage	Potenza Power	Corrente Current	Portata aria Air flow	Protezione Protection	Rumorosità Noise Level	Peso Weight
Tipo-Type	l	V	W	A	m ³ /h	IP	dB(A)	Kg
BC 390/2 12	8	12	240	20	2.800	68	86	25
BC 390/2 24		24		10				

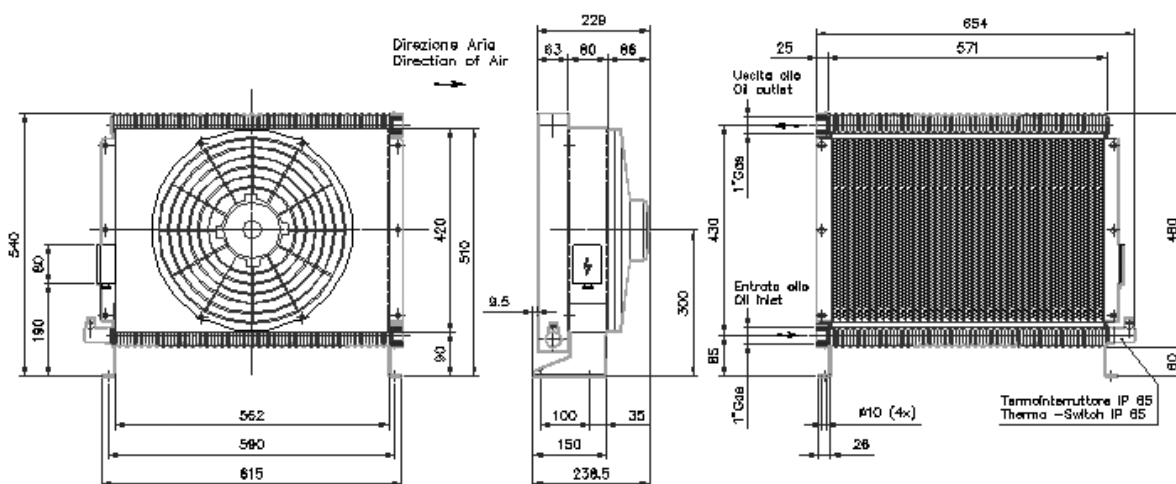

SERIE BC

resino
22

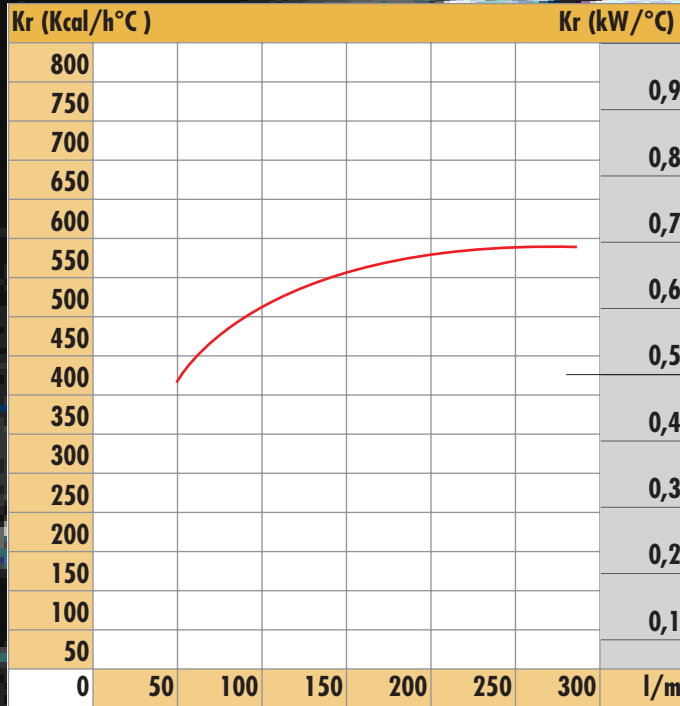

**DIAGRAMMA DI RENDIMENTO
PERFORMANCE DIAGRAM**

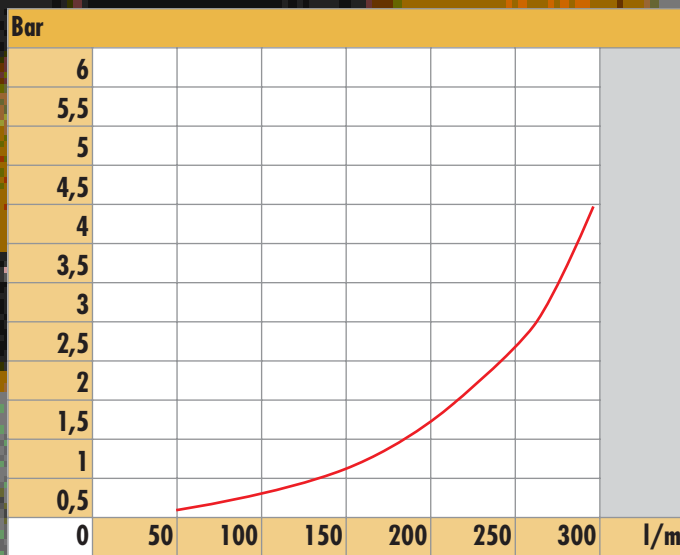

**DIAGRAMMA PERDITE DI CARICO
LOSS PRESSURE DIAGRAM**

22	30	46	68	100	150	220
0,6	1	1,5	2,3	3,5	5	7

**FATTORE DI CORREZIONE
CORRECTION FACTOR**

BC 390/2 MONOFASE TRIFASE



**DIMENSIONI E CARATTERISTICHE
TECNICHE NON IMPEGNATIVE
DIMENSIONS AND TECHNICAL
CHARACTERISTICS ARE NOT BINDING**

BC 390/2	Portata olio Oil flow	Capacità Capacity	Tensione Voltage	Frequenza Frequency	Potenza Power	Corrente Current	Portata d'aria Air flow	Protezione Protection	Rumorosità Noise Level	Peso Weight
Tipo-Type		l	V	Hz	W	A	m ³ /h	IP	dB(A)	Kg
BC 390/2 monofase	50-300	8	230	50/60	310	1,35	2.500	IP	73	30
BC 390/2 trifase			230/400		135/185					

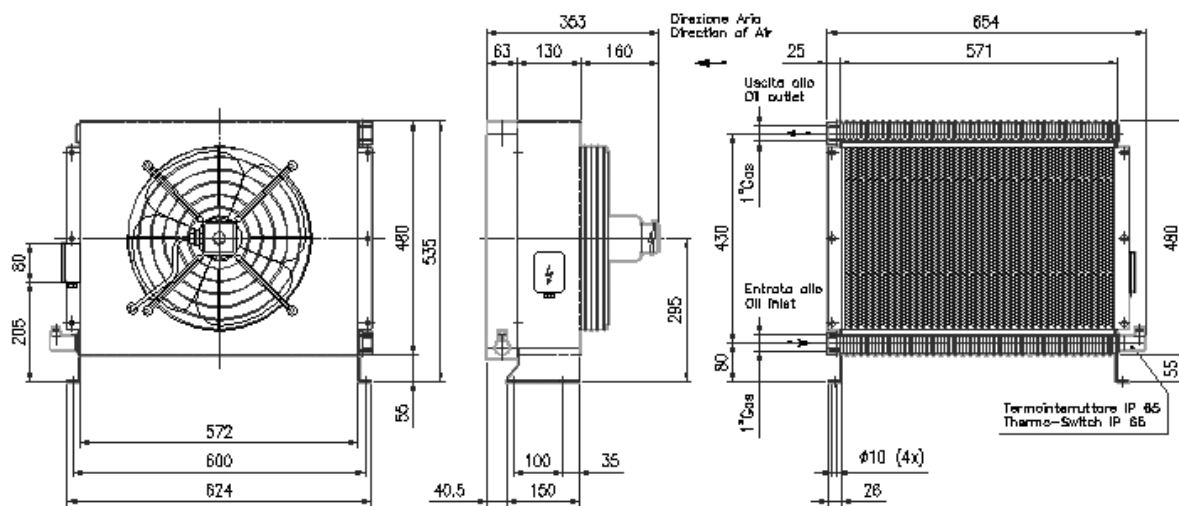

SERIE BC

	BC	250	24	47	I	BP
SERIE BC						
TIPO DI SCAMBIATORE COOLER TYPE						
210						
250						
250/2						
390						
390/2						
VOLTAGGIO MOTORE MOTOR VOLTAGE						
12 = 12V DC						
24 = 24V DC						
01 = AC monofase						
03 = AC trifase						
TERMOSTATO THERMO-SWITCH						
47 = 47-36°C						
60 = 60-49°C						
Non indicando nulla si intende senza termostato <i>If nothing is indicated it will be understood without thermo-switch</i>						
ALLESTIMENTO EQUIPMENT						
I = con impianto elettrico <i>I = with electrical system</i>						
Non indicando nulla si intende senza impianto elettrico <i>If nothing is indicated it will be understood without electrical system</i>						
BY PASS INTEGRATO INTEGRATED BY PASS VALVE						
BP = con by-pass <i>BP = with by-pass</i>						

24

COSTANTE SESINO SPA
VIA MONZA, 150
20060 GESSATE (MI)
+39 02 95380334
FAX +39 02 95780528
info@sesino.com
www.sesino.com

